

TYPICAL SECTION

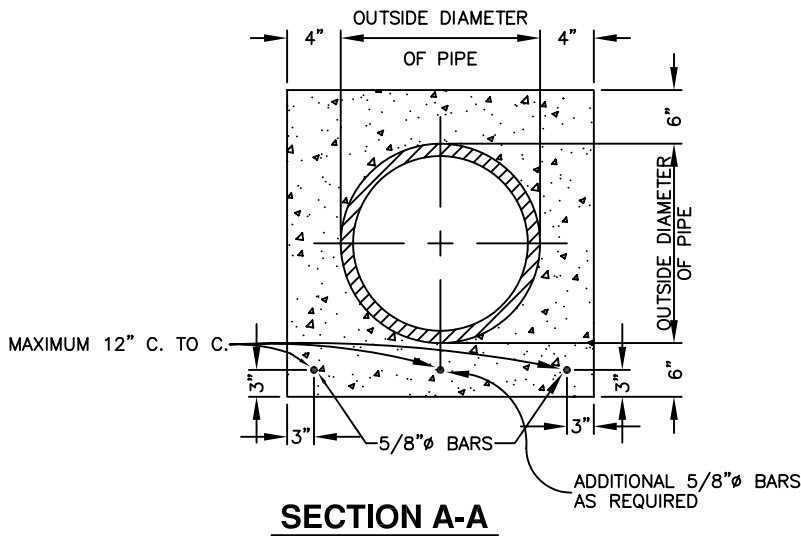

NOTES:
 THIS DETAIL TO BE APPLIED
 IN CASES DESIGNATED BY
 THE COUNTY ENGINEER.

Spec's By _____
Drawn By <u>J. SHIELDS</u>
APPROVED BY _____

COUNTY OF MADERA
CONCRETE SUPPORT FOR UNDERCUT PIPELINES (12" OR LARGER)

Date 7-1-81
Scale NONE
Drawing No. S-6

REVISIONS	8/1/02						
-----------	--------	--	--	--	--	--	--